

IELTS

INTERNATIONAL ENGLISH LANGUAGE TESTING SYSTEM

ACADEMIC READING

TIME ALLOWED: 1 Hour

NUMBER OF QUESTIONS: 38

Instructions

ALL ANSWERS MUST BE WRITTEN ON THE ANSWER SHEET

The test is divided as follows:

- | | |
|---------------------|----------------|
| - Reading Passage 1 | Question 1-11 |
| - Reading Passage 2 | Question 12-25 |
| - Reading Passage 3 | Question 26-38 |

Start at the beginning of the test and work through it. You should answer all the questions. If you cannot do a particular question leave it and go on to the next. You can return to it later.

READING PASSAGE 1

You should spend about 20 minutes on Questions 1-11 which are based on Reading Passage 1 on pages 2 and 3.

The Spectacular Eruption of Mount St. Helens

A The eruption in May 1980 of Mount St. Helens, Washington State, astounded the world with its violence. A gigantic explosion tore much of the volcano's summit to fragments; the energy released was equal to that of 500 of the nuclear bombs that destroyed Hiroshima in 1945.

B The event occurred along the boundary of two of the moving plates that make up the Earth's crust. They meet at the junction of the North American continent and the Pacific Ocean. One edge of the continental North American plate over-rides the oceanic Juan de Fuca micro-plate, producing the volcanic Cascade range that includes Mounts Baker, Rainier and Hood, and Lassen Peak as well as Mount St. Helens.

C Until Mount St. Helens began to stir, only Mount Baker and Lassen Peak had shown signs of life during the 20th century. According to geological evidence found by the United States Geological Survey, there had been two major eruptions of Mount St. Helens in the recent (geologically speaking) past: around 1900 B.C., and about A.D. 1500. Since the arrival of Europeans in the region, it had experienced a single period of spasmodic activity, between 1831 and 1857. Then, for more than a century, Mount St. Helens lay dormant.

D By 1979, the Geological Survey, alerted by signs of renewed activity, had been monitoring the volcano for 18 months. It warned the local population against being deceived by the mountain's outward calm, and forecast that an eruption would take place before the end of the century. The inhabitants of the area did not have to wait that long. On March 27, 1980, a few clouds of smoke formed above the summit, and slight tremors were felt. On the 28th, larger and darker clouds, consisting of gas and ashes, emerged and climbed as high as 20,000 feet. In April a slight lull ensued, but the volcanologists remained pessimistic. Then, in early May, the northern flank of the mountain bulged, and the summit rose by 500 feet.

E Steps were taken to evacuate the population. Most campers, hikers, timbercutters left the slopes of the mountain. Eighty-four-year-old Harry Truman, a holiday lodge owner who had lived there for more than 50 years, refused to be evacuated, in spite of official and public, including an entire class of school children, wrote to him, begging him to leave. He never did.

F On May 18, at 8.32 in the morning, Mount St. Helens blew its top. literally. Suddenly, it was 1300 feet shorter than it had been before its growth had begun. Over half a cubic mile of rock had disintegrated . At the same moment, an earthquake with an intensity of 5 on the Richter scale was recorded. It triggered an avalanche of snow and ice. mixed with hot rock-the entire north face of the mountain had fallen away. A wave of scorching volcanic gas and rock fragments shot horizontally from the volcano's riven flank, at an inescapable 200 miles per hour. As the sliding ice and snow melted, it touched off devastating torrents of mud and debris, which destroyed all life in their path. Pulverised, which destroyed all life in their path. Pulverised rock climbed as a dust cloud into the atmosphere. Finally, viscous lava, accompanied by burning clouds of ash and gas, welled out of volcano's new crater, and from lesser vents and cracks in its flanks.

G Afterwards, scientists were able to analyse the sequence of events. First, magmamolten rock-at temperatures above 2000°F. had surged into the volcano from the Earth's mantle. The build-up was accompanied by an accumulation of gas, which increased as the mass of magma grew. It was the pressure inside the mountain that made it swell. Next, the rise in gas pressure caused a violent decompression. Which ejected the shattered summit like a cork from a shaken soda bottle. With the summit gone, the molten rock within was released in a jet of gas and fragmented magma, and lava welled from the crater.

H The effects of the Mount St. Helens eruption were catastrophic. Almost all the trees of the surrounding forest, mainly Douglas firs. were flattened. and their branches and bark ripped off by the shock wave of the explosion. Ash and mud spread over nearly 200 square miles of country. All the towns and settlements in the area were smothered in an even coating of ash. Volcanic ash silted up the Columbia River 35 miles away, reducing the debris that accumulated at the foot of the volcano reached a depth. in places, of 200 feet.

I The eruption of Mount St. Helens was one of the most closely observed and analysed in history. Because geologists had been expecting the event, they were able to amass vast amounts of technical data when it happened. Study of atmospheric particles formed as a result of the explosion showed that droplets of sulphuric acid, acting as a screen between the Sun and the Earth's surface, caused a distinct drop in temperature. There is no doubt that the activity of Mount St. Helens and other volcanoes since 1980 has influenced our climate . Even so, it has been calculated that the quantity of dust ejected by Mount St. Helens - a quarter of a cubic mile- was negligible in comparison with that thrown out by earlier eruptions, such as that of Mount Katmai in Alaska in 1912 (three cubic miles). The volcano is still active. Lava domes have formed inside the new crater, and have periodically burst. The threat of Mount St Helens lives on.

.

Questions 1 and 2

Reading Passage 1 has 9 paragraphs labelled A-I

Answer questions 1 and 2 by writing the appropriate letter **A-I** in boxes 1 and 2 on your answer sheet.

<i>Example</i>	<i>Answer</i>
Which paragraph compares the eruption to the energy released by nuclear bomb?	A

- Which paragraph describes the evacuation of the mountain?
- Which paragraph describes the moment of the explosion of Mount St. Helens?

Questions 3 and 4

- What are the dates of the **TWO** major eruptions of Mount St. Helens before 1980?

Write **TWO** dates in box 3 on your answer sheet.

- How do scientists know that the volcano exploded around the two dates above?

Using **NO MORE THAN THREE WORDS**, write your answer in box 4 on your answer sheet

Questions 5-8

Complete the summary of events below leading up to the eruption of Mount St. Helens. Choose **NO MORE THAN THREE WORDS** from the passage for each answer.

Write your answers in boxes 5-8 on your answer sheet.

In 1979 the Geological Survey warned ... (5) ... to expect a violent eruption before the end of the century. The forecast was soon proved accurate. At the end of March there were tremors and clouds formed above the mountain. This was followed by a lull, but in early May the top of the mountain rose by ... (6)... . People were ...(7) ... from around the mountain. Finally, on May 18th at ...(8) ..., Mount St. Helens exploded.

Question 9 and 10

Complete the table below giving evidence for the power of the Mount St. Helens eruption.

Write your answers in boxes 9 and 10 on your answer sheet.

Item	Equivalent to
<i>Example</i> The energy released by the explosion of Mount St. Helens	<i>Answer</i> 500 nuclear bombs
The area of land covered in mud or ash	...(9)...
The quantity of dust ejected	...(10)...

Question 11

Choose the appropriate letter **A-D** and write it in box 11 on your answer sheet.

- According to the text the eruption of Mount St. Helens and other volcanoes has influenced our climate by ...
 - increasing the amount of rainfall.
 - heating the atmosphere.
 - cooling the air temperature.
 - causing atmospheric storms.

READING PASSAGE 2

You should spend about 20 minutes on **Questions 12-25** which are based on Reading Passage 2 on pages 6 and 7.

Questions 12-16

Reading Passage 2 has seven paragraphs A-G.

Choose the most suitable headings for paragraphs B-E and G from the list of heading below.

Write the appropriate numbers (i-x) in boxes 12-16 on your answer sheet.

NB There are more headings than paragraphs so you will not use all of them.

You may use any of the headings more than once.

List of Headings

- (i) The effect of changing demographics on organisations
- (ii) Future changes in the European workforce
- (iii) The unstructured interview and its validity
- (iv) The person-skills match approach to selection
- (v) The implications of a poor person-environment fit
- (vi) Some poor selection decisions
- (vii) The validity of selection procedures
- (viii) The person-environment fit
- (ix) Past and future demographic changes in Europe
- (x) Adequate and inadequate explanations of organisational failure

Example	Paragraph A	Answer (x)
12. Paragraph B		
13. Paragraph C		
14. Paragraph D		
15. Paragraph E		
Example	Paragraph F	Answer (ix)
16. Paragraph G		

PEOPLE AND ORGANISATIONS: THE SELECTION ISSUE

A In 1991, according to the Department of Trade and Industry, a record 48,000 British companies went out of business. When businesses fail, the post-mortem analysis is traditionally undertaken by accountants and market strategists. Unarguably organisations do fail because of undercapitalisation, poor financial management, adverse market conditions etc. Yet, conversely, organisations with sound financial backing, good product ideas and market acumen often underperform and fail to meet shareholders' expectations. The complexity, degree and sustainment of organisational performance requires an explanation which goes beyond the balance sheet and the "paper conversion" of financial inputs into profit making outputs. A more complete explanation of "what went wrong" necessarily must consider the essence of what an organisation actually is and that one of the financial inputs, the most important and often the most expensive, is *people*.

B An organisation is only as good as the people it employs. Selecting the right person for the job involves more than identifying the essential or desirable range of skills, educational and professional qualifications necessary to perform the job and then recruiting the candidate who is most likely to possess these

skills or at least is perceived to have the ability and predisposition to acquire them. This is a purely person/skills match approach to selection.

C Work invariably takes place in the presence and/or under the direction of others, in a particular organisational setting. The individual has to "fit" in with the work environment, with other employees, with the organisational climate, style or work, organisation and culture of the organisation. Different organisations have different cultures (Cartwright & Cooper, 1991; 1992). Working as an engineer at British Aerospace will not necessarily be a similar experience to working in the same capacity at GEC or Plessey.

D Poor selection decisions are expensive. For example, the costs of training a policeman are about £ 20,000 (approx. US\$ 30,000). The costs of employing an unsuitable technician on an oil rig or in a nuclear plant could, in an emergency, result in millions of pounds of damage or loss of life. The disharmony of a poor person-environment fit (PE-fit) is likely to result in low job satisfaction, lack of organisational commitment and employee stress, which affect organisational outcomes i.e. productivity, high labour turnover and absenteeism, and individual outcomes i.e. physical, psychological and mental well-being.

E However, despite the importance of the recruitment decision and the range of sophisticated and more objective selection techniques available, including the use of psychometric tests, assessment centres etc., many organisations are still prepared to make this decision on the basis of a single 30 to 45 minute unstructured interview. Indeed, research has demonstrated that a selection decision is often made within the first four minutes of the interview. In the remaining time, the interviewer then attends exclusively to information that reinforces the initial "accept" or "reject" decision. Research into the validity of selection methods has consistently demonstrated that the unstructured interview, where the interviewer asks any questions he or she likes, is a poor predictor of future job performance and fares little better than more controversial methods like graphology and astrology. In times of high unemployment,! recruitment becomes a "buyer's market" and this was the case in Britain during the 1980s.

F The future, we are told, is likely to be different. Detailed surveys of social and economic trends in the European community show that Europe's population is falling and getting older, The birth rate in the Community is now only three-quarters of the level needed to ensure replacement of the existing population. By the year 2020, it is predicted that more than one in four Europeans will be aged 60 or more and barely one in five will be under 20. In a five-year period between 1983 and 1988 the Community's female workforce grew by almost six million. As a result, 51% of all women aged 14 to 64 are now economically active in the labour market compared with 78% of men.

G The changing demographics will not only affect selection ratios. They will also make it increasingly important for organisations wishing to maintain their competitive edge to be more responsive and accommodating to the changing needs of their workforce if they are to retain and develop their human resources. More flexible working hours, the opportunity of work from home or job share, the provision of childcare facilities etc., will play a major role in attracting and retaining staff in the future.

Questions 17-22

Do the following statements agree with the views of the writer in Reading Passage 2?

In boxes 17-22 on your answer sheet write

- YES** if the statement agrees with the writer
- NO** if the statement does not agree with the writer
- NOT GIVEN** if there is no information about this in the passage

- 17. Organisations should recognise that their employees are a significant part of their financial assets.
- 18. Open-structured 45 minute interviews are the best method to identify suitable employees.
- 19. The rise in the female workforce in the European Community is a positive trend.
- 20. Graphology is a good predictor of future job performance.
- 21. In the future, the number of people in employable age groups will decline.
- 22. In 2020, the percentage of the population under 20 will be smaller than now.

Questions 23-25

Complete the notes below with words taken from Reading Passage 2. Use **NO MORE THAN ONE or TWO WORDS** for each answer.

Write your answers in boxes 23-25 on your answer sheet.

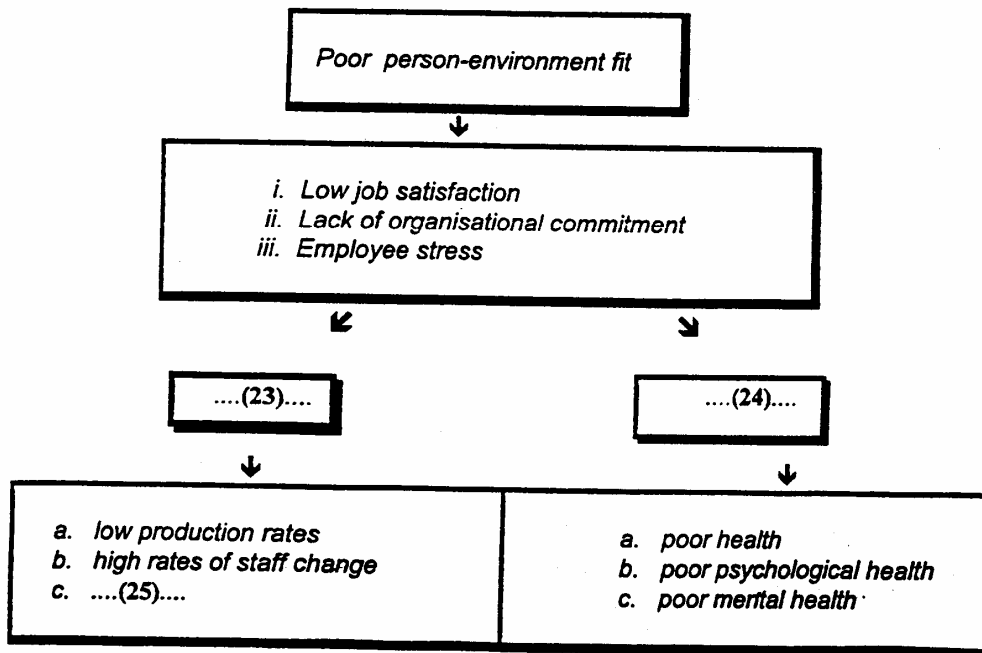

READING PASSAGE 3

You should spend about 20 minutes on *Questions 26-38* which are based on *Reading Passage 3* on pages 9 and 10.

"The Rollfilm Revolution"

The introduction of the dry plate process brought with it many advantages. Not only was it much more convenient, so that the photographer no longer needed to prepare his material in advance, but its much greater sensitivity made possible a new generation of cameras. Instantaneous exposures had been possible before, but only with some difficulty and with special equipment and conditions. Now, exposures short enough to permit the camera to be held in the hand were easily achieved. As well as fitting shutters and viewfinders to their conventional stand cameras, manufacturers began to construct smaller cameras intended specifically for hand use.

One of the first designs to be published was Thomas Bolas' s 'Detective' camera of 1881. Externally a plain box, quite unlike the folding bellows camera typical of the period, it could be used unobtrusively. The name caught on, and for the next decade or so almost all hand cameras were called ' Detectives'. Many of the new designs in the 1880s were for magazine cameras, in which a number of dry plates could be pre-loaded and changed one after another following exposure. Although much more convenient than stand cameras, still used by most serious workers, magazine plate cameras were heavy, and required access to a darkroom for loading and processing the plates. This was all changed by a young American bank clerk turned photographic manufacturer, George Eastman, from Rochester, New York.

Eastman had begun to manufacture gelatine dry plates in 1880, being one of the first to do so in America. He soon looked for ways of simplifying photography, believing that many people were put off by the complication and messiness. His first step was to develop, with the camera manufacturer William H. Walker, a holder for a long roll of paper negative 'film'. This could be fitted to a standard plate camera and up to forty-eight exposures made before reloading. The combined weight of the paper roll and the holder was far less than the same number of glass plates in their tight wooden holders. Although roll-holders had been made as early as the 1850s, none had been very successful because of the limitations of the photographic materials then available. Eastman's rollable paper film was sensitive and gave negatives of good quality; the Eastman-Walker roll-holder was a great success.

The next step was to combine the roll-holder with a small hand camera; Eastman's first design was patented with an employee, F. M. Cossitt, in 1886. It was not a success. Only fifty Eastman detective cameras were made, and they were sold as a lot to a dealer in 1887; the cost was too high and the design too complicated. Eastman set about developing a new model, which was launched in June 1888. It was a small box, containing a roll of paperbased stripping film sufficient for 100 circular exposures 6 cm in diameter. Its operation was simple: set the shutter by pulling a wire string; aim the camera using the V line

impression in the camera top; press the release button to activate the exposure; and turn a special key to wind to the film. A hundred exposures had to be made, so it was important to record each picture in the memorandum book provided, since there was no exposure counter. Eastman gave his camera the invented name 'Kodak'-which was easily pronounceable in most languages. and had two Ks which Eastman felt was a firm, uncompromising kind of letter.

The importance of Eastman's new roll-film camera was not that it was the first. There had been several earlier cameras, notably the 'America', first demonstrated in the spring of 1887 and on sale from early 1888. This also used a roll of negative paper, and had such refinements as a reflecting viewfinder and an ingenious exposure marker. The real significance of the first Kodak camera was that it was backed up by a developing and printing service. Hitherto, virtually all photographers developed and printed their own pictures. This required that facilities of a darkroom and the time and inclination to handle the necessary chemicals, make the prints and so on. Eastman recognized that not everyone had the resources or the desire to do this. When a customer had made a hundred exposures in the Kodak camera, he sent it to Eastman's factory in Rochester (or later in Harrow in England) where the film was unloaded, processed and printed, the camera reloaded and returned to the owner. "You Press the Button, We Do the Rest" ran Eastman's classic marketing slogan; photography had been brought to everyone. Everyone, that is, who could afford \$ 25 or five guineas for the camera and \$ 10 or two guineas for the developing and printing. A guinea (\$ 5) was a week's wages for many at the time, so this simple camera cost the equivalent of hundreds of dollars today.

In 1889 an improved model with a new shutter design was introduced, and it was called the No. 2 Kodak camera. The paper-based stripping film was complicated to manipulate, since the processed negative image had to be stripped from the paper base for printing. At the end of 1889 Eastman launched a new roll film on a celluloid base. Clear, tough, transparent and flexible, the new film not only made the rollfilm camera fully practical, but provided the raw material for the introduction of cinematography a few years later. Other, larger models were introduced, including several folding versions, one of which took pictures 21.6 cm x 16.5 cm in size. Other manufacturers in America and Europe introduced cameras to take the Kodak roll-films, and other firms began to offer developing and printing services for the benefit of the new breed of photographers.

By September 1889, over 5,000 Kodak cameras had been sold in the USA, and the company was daily printing 6-7,000 negatives, Holidays and special events created enormous surges in demand for processing: 900 Kodak users returned their cameras for processing and reloading in the week after the New York centennial celebration.

Questions 26-29

Do the following statements agree with the views of the writer in Reading Passage 3?

In boxes 26-29 on your answer sheet write

- YES** if the statement agrees with the writer
NO if the statement does agree with the writer
NOT GIVEN if there is no information about this in the passage

26. Before the dry plate process short exposures could only be achieved with cameras held in the hand.
 27. Stirn's America' camera lacked Kodak's developing service.
 28. The first Kodak film cost the equivalent of a week's wages to develop.
 29. Some of Eastman's 1891 range of cameras could be loaded in daylight.

Questions 30-34

Complete the diagram below. Choose **NO MORE THAN THREE WORDS** from the passage for each answer.

Write your answers in boxes 30-34 on your answer sheet.

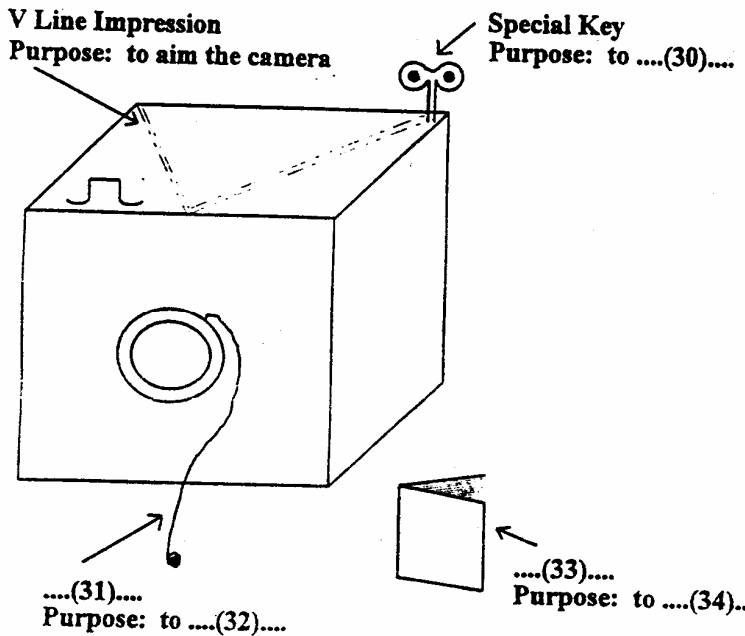

Questions 35-38

Complete the table below. Choose **NO MORE THAN THREE WORDS** from the passage for each answer.

Write your answers in boxes 35-38 on your answer sheet.

Year	Developments	Name of person/people
1880	Manufacture of gelatine dry plates(35)....
1881	Release of 'Detective' camera	Thomas Bolas
....(36)....	The roll-holder combined with(37)....	Eastman and F.M. Cossitt
1889	Introduction of model with(38)....	Eastman

ACADEMIC READING-ANSWER KEY
Each question correctly answered scores 1 mark.

Reading Passage 1, Questions 1-11
1. E
2. F
3. 1900 B.C. AND A.D. 1500 (<i>Both for 1 mark.</i>) NOT 1900 AND 1500
4. (according to/from)geological evidence/signs/data
5. (the) local population //inhabitants
6. 500/five hundred feet/ft
7. evacuated
8. 8.32 (a.m. /in the morning)
9. (nearly)200 square miles NOT 200 miles
10. (a)quarter/1/4 of (a) cubic mile
11. C
Reading Passage 2, Questions 12-25
12. (iv)
13. (viii)
14. (v)
15. (iii)
16. (i)
17. YES
18. NO
19. NOT GIVEN
20. NO
21. YES
22. YES
23. organisational outcomes
24. individual outcomes
25. absenteeism
Reading Passage 3, Questions 26-38
26. NO
27. YES
28. NO
29. NOT GIVEN
30. wind on (the) film_
31. (a) wire string
32. set (the) shutter
33. (the) memorandum book
34. record each picture/exposure
35. (George) Eastman
36. 1886
37. (a) (small) hand camera
38. (a) new shutter(design)

IELTS

INTERNATIONAL ENGLISH LANGUAGE TESTING SYSTEM

GENERAL TRAINING READING

TIME ALLOWED: 1 Hour

NUMBER OF QUESTIONS: 38

Instructions

ALL ANSWERS MUST BE WRITTEN ON THE ANSWER SHEET

The test is divided as follows:

- | | |
|---------------------|-----------------|
| - Reading Passage 1 | Questions 1-11 |
| - Reading Passage 2 | Questions 12-25 |
| - Reading Passage 3 | Questions 26-38 |

Start at the beginning of the test and work through it. You should answer all the questions. If you cannot do a particular question leave it and go on to the next. You can return to it later.

SECTION 1

Questions 1-14

Questions 1-4

There are six job advertisements A-F on the opposite page.

Answer the questions below by writing the letters of the appropriate advertisements in boxes 1-4 on your answer sheet.

Example

Which job is in a travel agent's ?

Answer

D

1. Which job is in a hotel?
2. Which job is for someone to look after a child ?
3. Which **TWO** advertisements are for waiters?
4. Which **TWO** jobs would particularly like a German speaker?

A

Restaurant
Supervisor
Waiting Staff
Telephonist

The ideal candidates must have relevant experience gained in a high quality hotel.
Please call
Personnel on 071-722-7722, or send your CV to: Regents Park Hilton. Lodge Road, London NW8 7JT
LONDON
REGENTS PARK
HILTON

B

USE YOUR
LANGUAGES AND EARN
£ 450 - £ 1200 P.W.

We are one of the largest business publishers in Europe and have limited vacancies for intelligent young people in our London advertisement sales office. Enquiries from German, Spanish and Eastern. European speakers especially welcome. Phone Andrew Warburton on
071 753 4300

C

SECRETARY
Busy Chartered
Accountants require
experienced/efficient
secretary. Accounts, typing experience, and an excellent
telephone manner essential, shorthand useful.
Please send CV to:
Box No. 9246
c/o Evening Standard
Classified
2 Derry Street
Kensington W8 5EE
.....

D

**TRAVEL
COMPANY**
Vacancy for self--confident person to look after
bookings for our Caribbean Hotels. Salary based on
applicant's experience & suitability. Please send CV
to Ian Taplin, MRI Ltd, 9 Galena Road, London,
W60 LX

E

NANNY WANTED
for 9 month old handful. Artistic/Prof household
Notting Hill. 3 days per week. Some hours flexibility
req'd
Knowledge
German/Hungarian advantage not essential 071 221
7375

F

Join the Stars!
Food Servers
The biggest and busiest restaurant in London is seeking
additional stars for its team of dedicated professionals. If
you have experience in high volume restaurants and are
looking a challenge, then come on down for an audition.
**Interview day is on Friday 6th May from 12 noon to
7pm.**
**Planet Hollywood is located at 13 Coventry Street,
London, W1**

Questions 5-10

Read the page from a UK telephone directory on the opposite page.

Answer the questions below by writing the appropriate telephone numbers in boxes 5-10 on your answer sheet.

What should you dial if ...

Example you want to speak to the International Operator?	Answer 123
--	-----------------------------

5. there is something wrong with your telephone?
6. there has been an accident and you want to call an ambulance?
7. you want to find out a number in a foreign country?
8. you want to know how much telephone calls cost?
9. you want to purchase an answer-phone machine?
10. you want to use a credit card to pay for a telephone call?

Operator Services	101
The operator is there to help you if you have difficulty making a call or if you want to use any of our special call services. These include: ALARM CALLS * ADVICE OF DURATION CHARGE * CREDIT CARD CALLS * FIXED TIME CALLS * FREEFONE CALLS * PERSONAL CALLS * TRANSFERRED CHARGE CALLS * SUBSCRIBER CONTROLLED TRANSFER. For details of charges see our free leaflet. Dial 101 and ask for financial services.	
International Operator	123
See Section 3 (international) for details.	
Directory Enquiries	142
Tell the operator the town you require. Have paper and pencil ready.	
International Directory Enquiries	130
Emergency	010
Tell the operator what service you want.	
Faults	166
Any fault should be reported to the local fault repair service	
Sales	170
Telemessage	190
If you have something special to say and prefer to say it in writing.	

International Telemessage	191
International Telegrams	192
You can send a telegram to most other countries.	
Maritime Service	200
SHIP' S TELEGRAM SERVICE * SHIP' S TELEPHONE SERVICE * INMARSAT SATELLITE SERVICE (DIAL 177). You can call or send a message to someone aboard ship by using our Maritime Services. For telephone calls to ships quote the name of the Coast Radio Station if known. For INMARSAT (Maritime Satellite) service dial 178. Give the ship's name, its identification number and ocean region, if known. International Directory Enquiries, code 130, can say if a ship is equipped for satellite service and provide the number.	
Any Other Call Enquiries	111

Questions 11-14

Read the following notice.

Using **NO MORE THAN THREE WORDS** form the passage answer the questions below.

Write your answers in boxes 11-14 on your answer sheet.

FIRE NOTICE

In the event of fire, the ALARM will ring. On hearing the fire alarm, all those in the West Wing should evacuate the building by staircase A. The assembly area for occupants of the West Wing is the staff car park at the rear of the building. All others assemble in the front courtyard.

Evacuate the building even if the alarm stops.

If you discover a fire, shout "FIRE" and operate the nearest fire alarm. Attack the fire with an extinguisher but to not take any risks. Inform reception by dialling 3333.

Example

Where is room 1?

Answer

the west wing

11. You are in room 101. Which staircase should you use to evacuate the building?

12. You are in room 201. Where should you wait outside after evacuating the building?

13. What should you do if the alarm stops?

14. Who should you contact if you discover a fire?

SECTION 2

Questions 15-27

Questions 15-20

Read "Information for New Students" below and answer the questions that follow.

Write your answers in boxes 15-20 on your answer sheet.

**HILTON ENGLISH LANGUAGE CENTRE
INFORMATION FOR NEW STUDENTS**

CLASS TIMES

9.00 am - 10.30 am

11.00 am - 12.30 pm

1.30 pm - 3.00 pm

The language Centre is open Monday to Friday. Each class has one afternoon free per week. On the first day go to the lecture hall to check your timetable.

SELF-ACCESS

The language laboratory (Room 1110) is open Monday to Friday from 3.15 pm to 5.00 pm for all full-time students. You can learn how to use the computers for language games or word-processing.

There are cassettes for students to borrow to practise their English. Go in and ask the teacher to show you.

If you plan to take public examinations, there are dictation and listening comprehension cassettes for you to practise with. There are cloze exercises on the computers. Ask your class teacher for a list of past exam essays. Students can borrow cassettes to take home but they must be returned after two days.

ATTENDANCE

All students on student visas are expected to attend classes regularly. Students who do not attend classes will be reported to OSS. Eighty per cent attendance is required for students to receive their certificate on completion of their course. It is also required by OSS for an extension to your visa.

Books

If students are given course books, the books are their responsibility. If a book is lost, the student will be expected to pay for it. If students wish to buy books, there is a bookshop in the college specialising in English books (Room 3520).

15. *When do classes begin and end on a full day?*
16. *How many afternoons does a class meet each week?*
17. *Where are the timetables displayed?*
18. *Who can use the language laboratory after classes?*
19. *Who is available in the self-access centre to help the students?*
20. *How much of a course must you attend according to visa restrictions?*

Questions 21-27

Read the passage below about a college in the city of Bath, written in 1985, and answer the questions that follow.

The College

The college has the advantage of location in one of the most attractive cities in the country. Within the city of Bath

it occupies modern buildings in a landscaped garden on Sion Hill, Lansdown and an adjacent Georgian Crescent, Somerset Crescent, which includes teaching and residential accommodation for post-graduate studies. It also occupies three houses in Sydney Place, which are used for studio and workshop accommodation for part-time courses in the Visual Arts and for the Foundation Course in Art and Design.

The Newton Park site is situated four miles west of Bath between the villages of Newton St Loe and Corston. Within the grounds are a Georgian mansion, where the college's central administration is located, an Elizabethan dairy, stables and the tower of a medieval manor house: all these older buildings have been adapted to present-day use. A new purpose-built Home Economics block was opened in January 1985. During 1986 a new Sports hall will be completed and new residential blocks are under construction to be completed ready for the start of the academic year in September 1986; a new Music block will be completed in 1987.

The Art and Design degree courses which are currently accommodated at Corsham, about nine miles east of Bath, will be moved to the Sion Hill site in Bath by September 1986 thus reinforcing Faculty and Course links.

The college courses are designed to take advantage of the special opportunities and circumstances provided by its environment. Students have available such resources as the Costume and fashion Research Centre, the Royal Photographic Centre and the Museum of American Domestic Life at Claverton. Concerts and recitals, including some given by staff and students, take place throughout the year in the Assembly Rooms.

The college uses buildings in five different places. Where are the following things located?

In boxes 21-27 on your answer sheet write

- NP* if something is located in Newton Park
- C* if something is located in Crescent
- SH* if something is located in Sion Hill
- SC* if something is located in Somerset Crescent
- SP* if something is located in Sydney Place

Example	Answer
<i>A landscaped garden</i>	<i>SH</i>

21. Central Administration
22. Home Economics Block
23. Art and Design Foundation Course
24. Art and Design Degree Course after 1986
25. Post-graduate Residences
26. Sports Hall
27. Music Block .

SECTION 3 Questions 28-38

Read the passage below and answer questions 28-38.

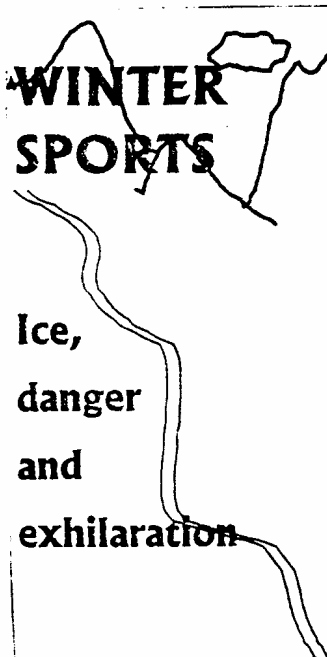

The 17th Winter Games, held in Norway in 1994, are part of an Olympic tradition which goes back almost 3,000 years. For more than 1,000 years the ancient Games were held, every four years, on hallowed ground near Mount Olympus, where the Greek gods were said to live.

The 'Olympics' brought together men from war-torn tribes and states in Greece and its colonies. A sacred truce was declared to allow men to travel to the games in safety. Women could not take part and were forbidden, on pain of death, even to attend the Games.

The ancient Olympics were abolished by the Roman Emperor Theodosius in 393 AD, after Greece had lost its independence. But the idea never died and the Frenchman Baron Pierre de Coubertin, an educator and scholar, founded the modern Olympics. His aim was to bring together, once every four years, athletes from all countries on the friendly fields of amateur sport. No account was to be taken of national rivalries, nor politics, race, religion, wealth or social status. The first modern Games were held in Athens in 1896, and four years later, in Paris, women began to take part. Although the winter Olympics did not begin until 1924, figure skating was part of the 1908 London summer Olympics, both skating and ice hockey were included in the Antwerp Games in 1920. But generally winter sports were felt to be too specialized. Only cold-weather countries had much experience of activities such as skiing—a means of transport overland across ice and snow during long winters. The Scandinavians, for whom skiing is a part of everyday life, had objected to a winter games. They feared it would threaten their own Nordic games, which had been held every four years since 1901. But the International Olympic Committee (IOC) agreed to stage an International Sports Week in Chamonix, France, in 1924. It was a success and the Scandinavians won 28 of the 43 medals, including nine golds. They dropped their objections and the event was retrospectively named the First Olympic Winter Games.

Apart from the Second World War period the Winter Olympics were held every four years, a few months before the summer Olympics. But in 1986 the IOC changed the schedule so that the summer and winter games would be held in different years. Thus, for the only time in history, the Lillehammer (Norway) Games took place just two years after the previous Winter Olympics which were held in Albertville, France.

Since the Winter Games began, 55 out of 56 gold medals in the men's nordic skiing events have been won by competitors from Scandinavia or the former Soviet Union. For teams from warm weather countries, cross-country skiing can pose problems. At the Calgary Games in 1988, one competitor in the 50-kilometre event was so slow

that race officials feared he was lost and sent out a search party. Roberto Alvarez of Mexico had never skied more than 20 kilometres before and finished 61st and last 52 minutes behind the 60th place.

Questions 28-31

Complete the table below. Write a date for each answer.

Write your answers in boxes 28-31 on your answer sheet,

	DATE	EVENT
	...(28)...	Ancient Olympics came to an end
	...(29)...	First women's events
<i>Example</i>	...1901...	First Nordic Games
	...(30)...	First winter team game included in Olympics
	...(31)...	First Winter Olympic Games

Questions 32-38

Look at the following statement. In boxes 32-38 on your answer sheet write

TRUE if the statement is true

FALSE if the statement is false

NOT GIVEN if the information is not given in the passage

- 32. *The spectators, as well as the participants, of the ancient Olympics were all male.*
- 33. *Only amateur athletes are allowed to compete in the modern Olympics.*
- 34. *The modern Olympics have always demonstrated the political neutrality intended by their founder*
- 35. *The Antwerp Games proved that winter sports were too specialized.*
- 36. *Cross-country skiing events are a specialty of cold-weather countries.*
- 37. *Only Scandinavians have won gold medals in men's winter Olympics nordic skiing events.*
- 38. *One Winter Olympics has succeeded another every four years since 1924 with a break only for the Second World War.*

GENERAL TRAINING READING-ANSWER KEY

Each question correctly answered scores 1 mark.

Section 1. Questions 1-14

1. A

2. E

3. A **AND** F (*both for 1 mark-any order*)

4. B **AND** E (*both for 1 mark-any order*)

5. 166

6. 010

7. 130

8. 101

9. 170

10. 101

11. (staircase) J

12. (in) (the) front courtyard

13. (still/continue to) evacuate (the building)

14. reception

Section 2. Questions 15-27

15. 9.00 (am) **AND** 3.00 (pm)/ nine (o'clock) **AND** three (o'clock) (both required for 1 mark)

16. 4/four

17. (the) lecture hall/room

18. (all) full-time students

19. (a/the) teacher

20. 80 / eighty % / per cent

21. NP

22. NP

23. SP

24. SH

25. SC

26. NP

27. NP

Section 3, Questions 28-38

28. 393(AD)

29. 1900

30. 1920

31. 1924

32. TRUE

33. NOT GIVEN

34. NOT GIVEN

35. FALSE

36. TRUE

37. FALSE

38. FALSE